

Service Interface Panel

Model SIP-1400

SECTION	PAGE #
1. OVERVIEW.....	1
2. APPLICATIONS	1
3. DESCRIPTION	1
4. INSTALLATION	3
5. TESTING & TROUBLESHOOTING	3
6. CUSTOMER SERVICE	3
7. WARRANTY AND REPAIRS	3
8. SPECIFICATIONS.....	4

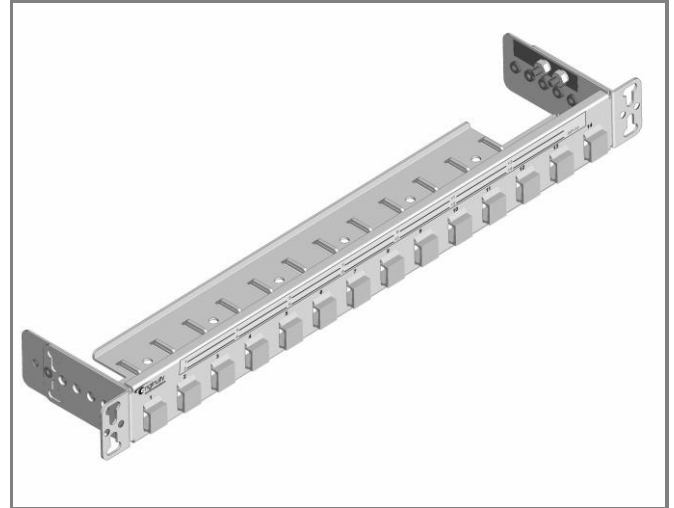

Figure 1. Service Interface Panel, SIP-1400

1. OVERVIEW

The Service Interface Panel (SIP), Model SIP-1400, is a modular interface for a variety of broadband services in a relay rack, equipment cabinet, or wall mounted configuration. The SIP can be used to terminate a combination of Ethernet, T1/E1, DS3, or other copper or fiber based services by selecting the appropriate snap-in coupler. The SIP-1400 panel comes standard with blank inserts where individual terminations can be installed as needed.

Document Status

This practice has been reissued to include an additional coupler and update the DRNG-U-2 model name in Section 8.

Product Features

- Carrier-class interface for high-speed services:
 - Ethernet 10/100 and GigE (RJ45)
 - T1/E1 (RJ48)
 - DS3 (BNC coax)
 - Video (F-81 coax)
 - Optical services (SC, LC, ST, MPO)
- Up to 14 circuits in a 1RU chassis
- Universal installation - 19" or 23" rack or wall mount
- Flexible service administration and cable management
- Heavy duty metal construction

2. APPLICATIONS

The versatility of the SIP makes it easy to organize and consolidate services in:

- Remote cabinets
- Cell sites
- Data centers
- Multi-dwelling units (MDUs)
- Commercial buildings

The SIP's snap-in couplers can be installed in any order or combination for efficient grooming of mixed services (see Figure 2). Front connections provide a convenient service access point, while rear connectors allow network cabling to be secured behind the panel.

3. DESCRIPTION

The front panel of the SIP-1400 accepts snap-in Keystone style couplers as shown in Figures 3 and 4. Twisted pair, coaxial, and fiber couplers can be ordered individually and inserted into the panel by the installer. Cutouts in the bottom of the rear cable tray provide additional access for ease of installation.

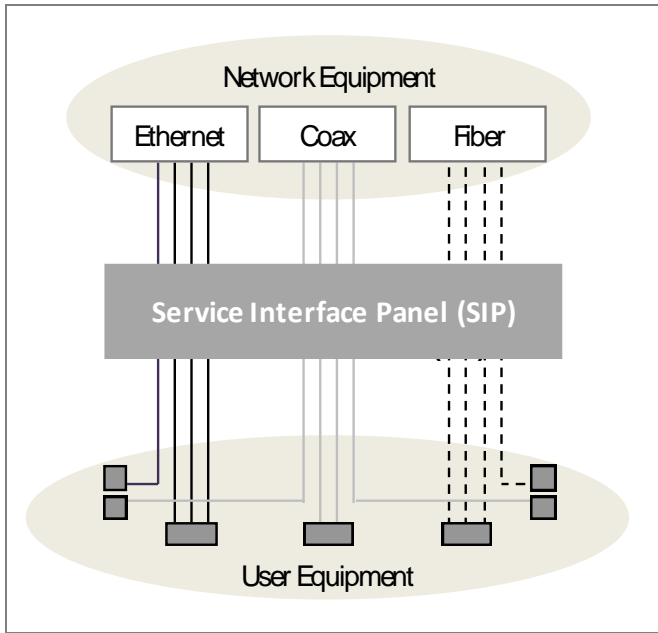

Figure 2. SIP application

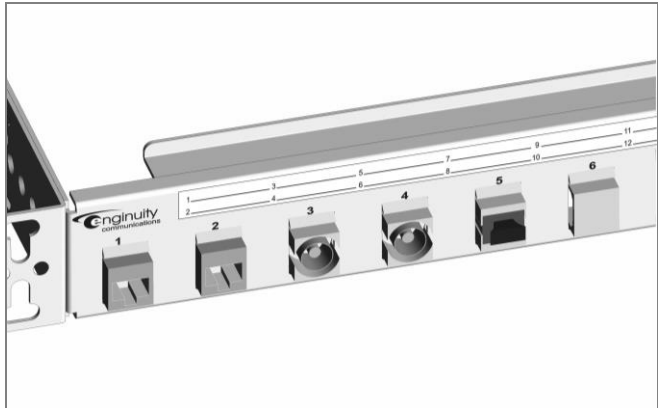

Figure 3. SIP couplers installed

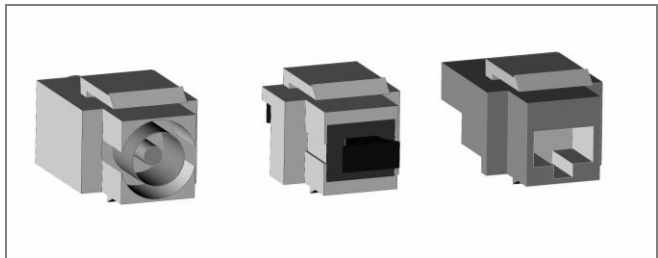

Figure 4. Example couplers (enlarged)

Mounting Options

The SIP-1400 is designed for universal installation and comes from the factory ready to install in a 23" relay rack. The mounting brackets are also adjustable for installation in a 19" rack (as shown in Figure 5), or reversible for wall mounting.

The unit comes from the factory with the mounting brackets positioned flush with the front of the panel. The brackets can be adjusted to position the front of the panel flush with the rails of a relay rack, or adjusted to protrude forward, depending on the installer's preference.

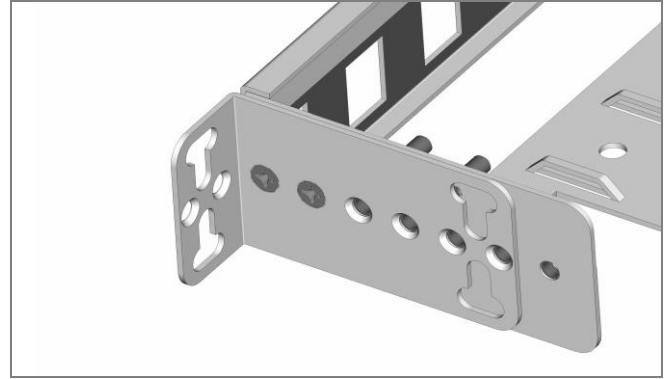

Figure 5. Mounting bracket

Construction

The SIP-1400 is 1RU (1.75 inches) in height. The chassis and mounting brackets are constructed of heavy-gauge steel and attached to a cable tray, shown in Figure 6, on the rear of the panel. The cable tray can be used to tie-wrap individual cables in a secure position for routing to network equipment.

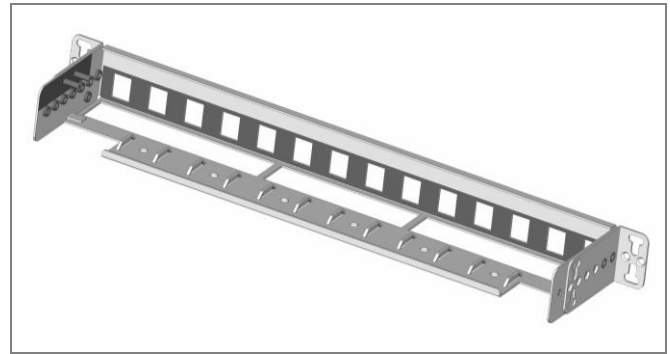

Figure 6. Rear cable tray

Circuit Designation

A circuit identification strip on the front of the SIP-1400 allows a technician to mark the physical positions of circuits terminated on the panel. The magnetic strip can be easily removed, marked appropriately, and put back in place.

4. INSTALLATION

The SIP-1400 is shipped with (4) 12-24 slotted hex-head mounting screws, (4) 10-32 Phillips pan-head machine screws, and twelve (12) tie-wraps.

Mounting

To install the SIP-1400 panel, adjust the mounting brackets for the desired rack width and use the (4) slotted hex-head or Phillips-head machine screws included with the panel to secure in a relay rack. The mounting brackets slots accommodate EIA standard rack rail spacing or 1" centered telco rail spacing. For wall-mount installations, either drywall or wood screws (not included) can be used.

Grounding

The SIP-1400 panel is equipped with two 8-32 ground posts, as shown in Figure 7. To ground the chassis, install a ground lug beneath the factory installed washers and hex nuts. Connect a ground wire of appropriate gauge to the ground lug, and attach the other end of the wire to a bonded ground point, per local procedures for network equipment.

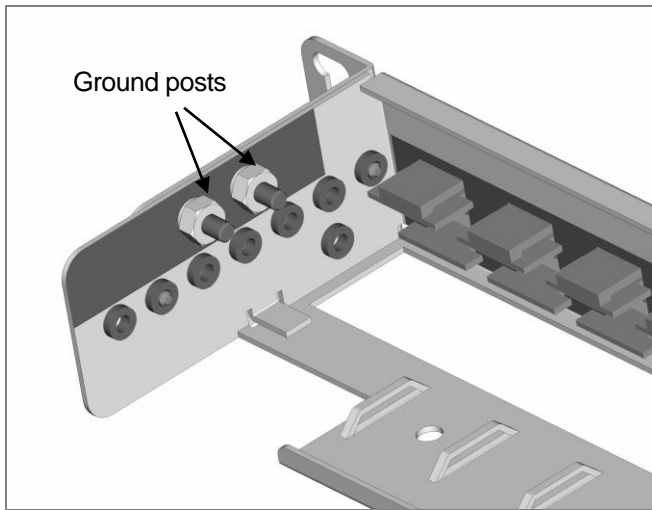

Figure 7. Chassis ground connector

Coupler Installation and Removal

Couplers are installed or removed by hand from the rear of the panel. Each coupler is held in place by angled tabs along the top and bottom of the coupler body. To install a coupler, tilt it back slightly while inserting it through the rectangular opening, until the lower tab clears the front of the panel. Then apply pressure to the upper tab and tilt the coupler body forward until it snaps in place.

To remove a coupler, apply pressure to the upper tab while tilting the coupler body backward. After the upper tab is freed, the coupler can be lifted and removed from the opening.

5. TESTING AND TROUBLESHOOTING

A test set can be connected to the front or rear jacks of the SIP-1400 to isolate and verify performance of attached cables and equipment.

6. CUSTOMER SERVICE

If technical or customer assistance is required, please contact Engenuity at the following address or phone number:

Engenuity Communications
3545 Stern Avenue
St. Charles, Illinois 60174
Toll Free: 1-800-980-3266
Local: (630) 444-0778
www.engenuitycom.com

7. WARRANTY & REPAIRS

Warranty

Engenuity warrants this product for one (1) year from date of purchase. Any attempt to repair or modify the equipment by anyone other than an authorized Engenuity representative will void the warranty.

This limited warranty does not cover any losses or damages resulting from shipment to or from the customer, or from improper installation, abuse, modifications, or unauthorized repair by other than Engenuity personnel.

Repair and Return

Engenuity equipment will be repaired or replaced without cost during the warranty period if the product is defective for any reason other than abuse, improper use, or improper installation. Before returning defective equipment, first request a Return Material Authorization (RMA) number from Engenuity. Once an RMA number is obtained, return the unit, freight prepaid, along with a brief description of the problem, to:

Engenuity Communications
3545 Stern Avenue
St. Charles, Illinois 60174
ATTN: Repair & Return Dept.

Replacements will be shipped in the fastest manner consistent with the urgency of the situation. Repair or replacement of faulty equipment beyond the warranty period is available for a nominal charge. Contact Engenuity for details.

8. SPECIFICATIONS

Chassis

PART NUMBER	SIP-1400 (shipped with 14 blank inserts installed)
HEIGHT	1.75 inches (1RU)
WIDTH	19.0 or 23.0 inches; adjustable mounting brackets
DEPTH	4 inches to 6 inches; adjustable mounting brackets
WEIGHT	29 oz., nominal

Keystone Couplers

PART NUMBER	FRONT CONNECTOR	REAR CONNECTOR	NOTES
CPL-5E-1	Cat5E RJ45	Cat5E RJ45	1) RJ45 jacks carry all 8 conductors and can be used as RJ48.
CPL-Q5E-1	Cat5E RJ45*	Cat5E RJ45*	
JCK-5E-KRO-1	Cat5E RJ45	KRONE®/110	2) Connectors marked with an asterisk (*) include gel coated contacts.
JCK-Q5E-KRO-1	Cat5E RJ45*	KRONE®/110	
CPL-6S-1	Cat6E RJ45	Cat6E RJ45	Fiber couplers accept single-mode or multi-mode fiber.
CPL-Q6S-1	Cat6E RJ45*	Cat6E RJ45*	
CPL-BNC-1	Coax BNC	Coax BNC	
CPL-F81-1	Coax F81	Coax F81	
CPL-LC-1	Fiber LC	Fiber LC	
CPL-LC-APC-1	Fiber LC-APC	Fiber LC-APC	
CPL-SC-1	Fiber SC	Fiber SC	
CPL-SC-APC-1	Fiber SC-APC	Fiber SC-APC	
CPL-ST-1	Fiber ST	Fiber ST	
CPL-MPO-APC-1	MPO APC Key Down	MPO APC Key Up	

KRONE is a registered trademark of ADC.

Couplers may be ordered in 10-packs

Accessories

PART NUMBER	DESCRIPTION
DRNG-U-2	Universal D-Ring for cable management